

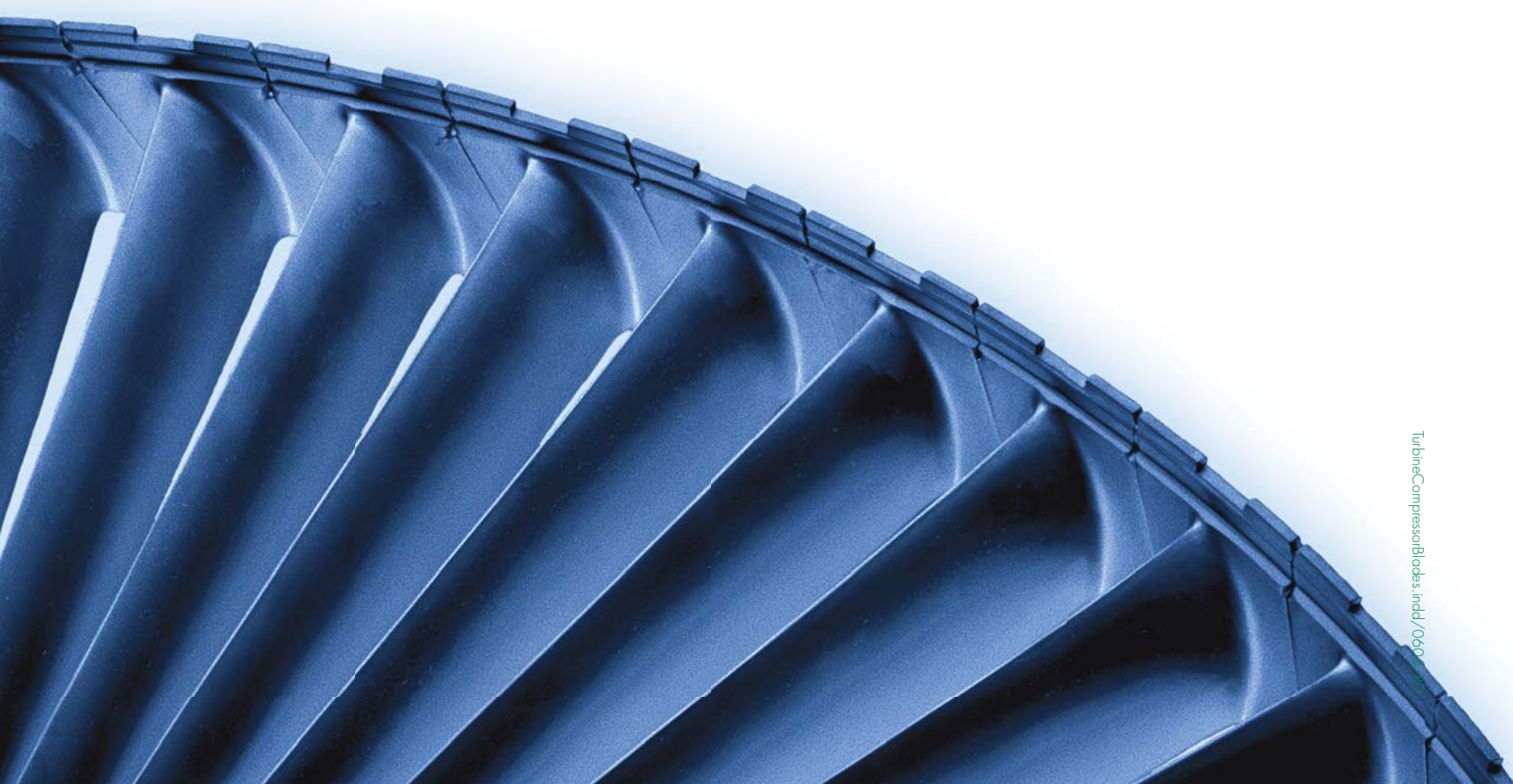

Huffman Grinder, Laser and Waterjet Technologies deliver exceptional technical & commercial results for manufacture and repair of a wide variety of flight and industrial gas turbine components.

WWW.HUFFMANCORP.COM
1-888-HUFFMAN

1050 HUFFMAN WAY
CLOVER, SC 29710 USA
TEL: 803-222-4561
FAX: 803-222-7599



TurbineCompressorBlades.indd/0600

HUFFMAN GRINDING APPLICATION

Turbine & Compressor Blades



EPCBN Wheel Pack Combining Multiple Operations on a Compressor Blade Root Form



WWW.HUFFMANCORP.COM
1-888-HUFFMAN

TECHNOLOGY THAT IS MORE PRODUCTIVE.

TURBINE BLADES AND COMPRESSOR BLADES in flight and industrial turbine engines require complicated, tight-tolerance “root form” profiles. Many types of blades also have additional complex geometry like Z-notch forms, seals, platforms, and locking grooves. These complex, tight-tolerance geometries are typically machined on blades by grinding.

For many years, the industry-wide standard method for grinding blades included:

- 3-axis machines
- Conventional abrasive wheels
- Table-mounted or over-the-wheel truing device
- Intermittent or continuous wheel truing
- Diamond Truing Roll
- Multiple, single-operation fixtures on the work table.
- Multiple operations done on separate grinding machines.



BENEFITS ▾

MULTI-AXIS POSITIONING AND CONTOURING

- Combining operations completes more geometry in a single machine cycle
- Fewer machines and less capital investment
- Fewer fixtures, less labor and less opportunity for process variation and scrap
- Less WIP

WHEEL TECHNOLOGY

- Use superabrasive or hybrid abrasive wheels where appropriate
- Lower *Total Abrasive Cost* per part
- Stable process
- Rapid Setups and changeovers
- Formed wheels and/or wheel packs

CONVENTIONAL GRINDING & SINGLE SETUP GRINDING: COSTLY AND INEFFICIENT

THE VARIABLE COSTS

Usually, conventional grinding only grinds one feature at a time – a costly method for higher precision parts. With a low G-ratio, conventional grinding wheels have a lower life and need to be changed frequently. These types of wheels are quickly consumed and difficult to handle during changeover. Also, truing costs far outweigh the cost of conventional grinding wheels. They require a diamond truing roll to be used frequently or even continuously. Conventional grinding coolant is water-based, and must be disposed of periodically.

THE COST OF THE PROCESS

Conventional grinding typically involves multiple, separate operations – sometimes multiple fixtures. Every fixture change introduces an opportunity for process variation or scrap. Although all grinding processes have some occurrence of wheel wear, conventional abrasive wheels have a very high wheel wear rate. The process must accommodate this wheel wear. Conventional grinding produces more grinding swarf – the majority of which is grinding wheel swarf.

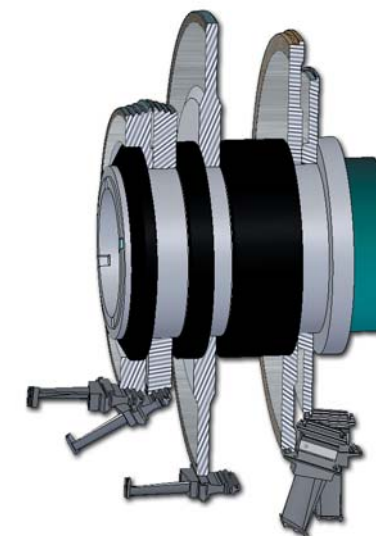

BY COMBINING OPERATIONS,
HUFFMAN MACHINES PRODUCE
**EXCEPTIONAL TECHNICAL &
COMMERCIAL RESULTS.**

WHY THE HUFFMAN APPROACH IS BETTER

- 5-axis machine can combine many operations into one grinding cycle.
- Huffman machines use fewer clampings which means there are fewer opportunities for process variation or scrap.
- Tolerance stack-up is reduced because Huffman machines grind components from a single set of location points.
- EPCBN and VitCBN wheels strongly prefer oil-based coolants. Because oil is recyclable it does not need to be dumped thereby lowering maintenance time and cost.
- EPCBN wheel packs require no truing. The machine cycle time is 100% grinding. VitCBN requires very infrequent truing.
- With a much higher G-ratio than conventional abrasive wheels, EPCBN and VitCBN wheels require little, if any, truing. Much less labor is required to change, true, and setup wheels.
- Huffman machines generate a more stable process because wheel truing is less frequent.
- Grinding swarf is relatively low – almost all workpiece material.
- When properly applied, Huffman machines:
 - Lower abrasive cost per part
 - Lower total cost per part
 - Create higher quality and less scrap
 - Lower total throughput time
 - Lower WIP